

1 **THREADED BODY**

Glass-fibre reinforced polyamide based (PA) SUPER-technopolymer.

2 **PLUNGER**

Black-oxide hardened steel or AISI 303 stainless steel.
Suggested tolerance for matching hole = H7.

3 **KNOB**

Polyamide based (PA) technopolymer, high-resilience, black colour or RAL 3000 red colour (C6), matte finish.

4 **SPRING**

AISI 302 stainless steel.

5 **LOCKING NUT**

NTT: Glass-fibre reinforced polyamide based (PA) SUPER-technopolymer.
Available also as accessory sold separately (see table).

6 **STANDARD EXECUTIONS**

- **PMT.101-A:** black-oxide steel plunger, without locking nut.
- **PMT.101-AK:** black-oxide steel plunger, with locking nut (supplied not assembled).
- **PMT.101-SST-A:** AISI 303 stainless steel plunger, without locking nut, not magnetic.
- **PMT.101-SST-AK:** AISI 303 stainless steel plunger, with locking nut (supplied not assembled), not magnetic.

7 **FEATURES AND APPLICATIONS**

- Lightness and high mechanical resistance of the product.
- The SUPER-technopolymer threaded body of the plunger offers a low friction factor to the plunger stroke; no lubricating maintenance is required.
- Anticorrosive material: suitable even in the presence of liquid or humidity (PMT.101-SST).
- Resistant to several cleaning cycles with solvents and other chemical agents, for this reason they are suitable for applications as in the pharmaceutical or food industry.
- The stop toothing (for the rest position) made out of SUPER-technopolymer: no risk of seizure or wear.

8 **ANOTHER STANDARD EXECUTION**

PMT.100: (see page 524) indexing plungers without rest position.

9 **ACCESSORIES ON REQUEST**

NTT: special glass-fibre reinforced polyamide based (PA) SUPER-technopolymer locking nut (see table).



ELESA Original design

ASSEMBLY INSTRUCTIONS

Make sure that no machining residues are left on the threaded hole for the assembly of PMT.101 indexing plunger (see fig. 1). Do not make any chamfering in the hole (see fig. 2). SUPER-technopolymer product based on ELESA technology, dimensions according to GN 617 standards as agreed with Otto Ganter GmbH Co. KG.

Fig.1

Fig.2

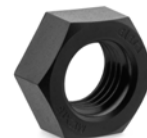
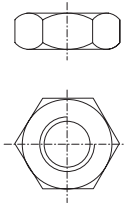
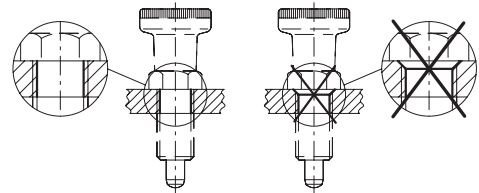

NTT

Code	Description
301083	NTT-M10x1
301085	NTT-M12x1,5
301087	NTT-M16x1,5
301089	NTT-M20x1,5

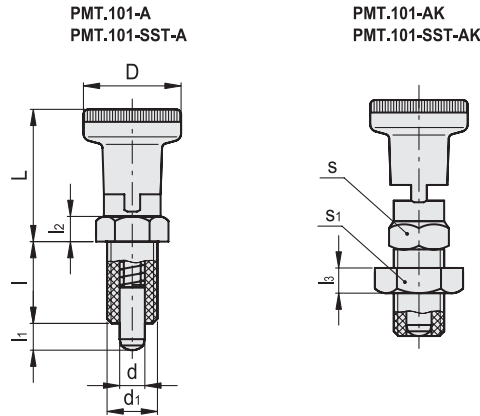

PMT.101-A

Code	Description	d Plunger -0.15-0.1 Hole H7	d1	L	D	l	l1	l2	s	[N]*	[N]#	Maximum tightening torque [Nm]	Static load at breakage F [N]	⚖
51601	PMT.101-5-M10x1-A	5	M10x1	29	21	17	5	5	12	7	17	5	2300	13
51601-C6	PMT.101-5-M10x1-A-C6	5	M10x1	29	21	17	5	5	12	7	17	5	2300	13
51602	PMT.101-6-M12x1,5-A	6	M12x1.5	35	25	20	6	6	14	9	24	10	3500	20
51602-C6	PMT.101-6-M12x1,5-A-C6	6	M12x1.5	35	25	20	6	6	14	9	24	10	3500	20
51611	PMT.101-8-M16x1,5-A	8	M16x1.5	43	31	26	8	8	19	11	30	18	5900	25
51611-C6	PMT.101-8-M16x1,5-A-C6	8	M16x1.5	43	31	26	8	8	19	11	30	18	5900	25
51612	PMT.101-10-M20x1,5-A	10	M20x1.5	48	31	33	10	10	22	19	45	25	7700	32
51612-C6	PMT.101-10-M20x1,5-A-C6	10	M20x1.5	48	31	33	10	10	22	19	45	25	7700	32

PMT.101-AK

51621	PMT.101-5-M10x1-AK	5	M10x1	29	21	17	5	5	7	12	16	7	17	5	2300	23
51621-C6	PMT.101-5-M10x1-AK-C6	5	M10x1	29	21	17	5	5	7	12	16	7	17	5	2300	23
51622	PMT.101-6-M12x1,5-AK	6	M12x1.5	35	25	20	6	6	8	14	19	9	24	10	3500	33
51622-C6	PMT.101-6-M12x1,5-AK-C6	6	M12x1.5	35	25	20	6	6	8	14	19	9	24	10	3500	33
51631	PMT.101-8-M16x1,5-AK	8	M16x1.5	43	31	26	8	8	10	19	24	11	30	18	5900	50
51631-C6	PMT.101-8-M16x1,5-AK-C6	8	M16x1.5	43	31	26	8	8	10	19	24	11	30	18	5900	50
51632	PMT.101-10-M20x1,5-AK	10	M20x1.5	48	31	33	10	10	11	22	30	19	45	25	7700	69
51632-C6	PMT.101-10-M20x1,5-AK-C6	10	M20x1.5	48	31	33	10	10	11	22	30	19	45	25	7700	69

PMT.101-SST-A



Code	Description	d Plunger -0.15-0.1 Hole H7	d1	L	D	l	l1	l2	s	[N]*	[N]#	Maximum tightening torque [Nm]	Static load at breakage F [N]	⚖
51651	PMT.101-SST-5-M10x1-A	5	M10x1	29	21	17	5	5	12	7	17	5	1800	13
51651-C6	PMT.101-SST-5-M10x1-A-C6	5	M10x1	29	21	17	5	5	12	7	17	5	1800	13
51652	PMT.101-SST-6-M12x1,5-A	6	M12x1.5	35	25	20	6	6	14	9	24	10	2900	20
51652-C6	PMT.101-SST-6-M12x1,5-A-C6	6	M12x1.5	35	25	20	6	6	14	9	24	10	2900	20
51661	PMT.101-SST-8-M16x1,5-A	8	M16x1.5	43	31	26	8	8	19	11	30	18	4400	25
51661-C6	PMT.101-SST-8-M16x1,5-A-C6	8	M16x1.5	43	31	26	8	8	19	11	30	18	4400	25
51662	PMT.101-SST-10-M20x1,5-A	10	M20x1.5	48	31	33	10	10	22	19	45	25	6800	32
51662-C6	PMT.101-SST-10-M20x1,5-A-C6	10	M20x1.5	48	31	33	10	10	22	19	45	25	6800	32

PMT.101-SST-AK

51671	PMT.101-SST-5-M10x1-AK	5	M10x1	29	21	17	5	5	7	12	16	7	17	5	1800	23
51671-C6	PMT.101-SST-5-M10x1-AK-C6	5	M10x1	29	21	17	5	5	7	12	16	7	17	5	1800	23
51672	PMT.101-SST-6-M12x1,5-AK	6	M12x1.5	35	25	20	6	6	8	14	19	9	24	10	2900	33
51672-C6	PMT.101-SST-6-M12x1,5-AK-C6	6	M12x1.5	35	25	20	6	6	8	14	19	9	24	10	2900	33
51681	PMT.101-SST-8-M16x1,5-AK	8	M16x1.5	43	31	26	8	8	10	19	24	11	30	18	4400	50
51681-C6	PMT.101-SST-8-M16x1,5-AK-C6	8	M16x1.5	43	31	26	8	8	10	19	24	11	30	18	4400	50
51682	PMT.101-SST-10-M20x1,5-AK	10	M20x1.5	48	31	33	10	10	11	22	30	19	45	25	6800	69
51682-C6	PMT.101-SST-10-M20x1,5-AK-C6	10	M20x1.5	48	31	33	10	10	11	22	30	19	45	25	6800	69

* Spring preload

Spring maximum load

